

# SERIES FAS SUCTION FILTERS

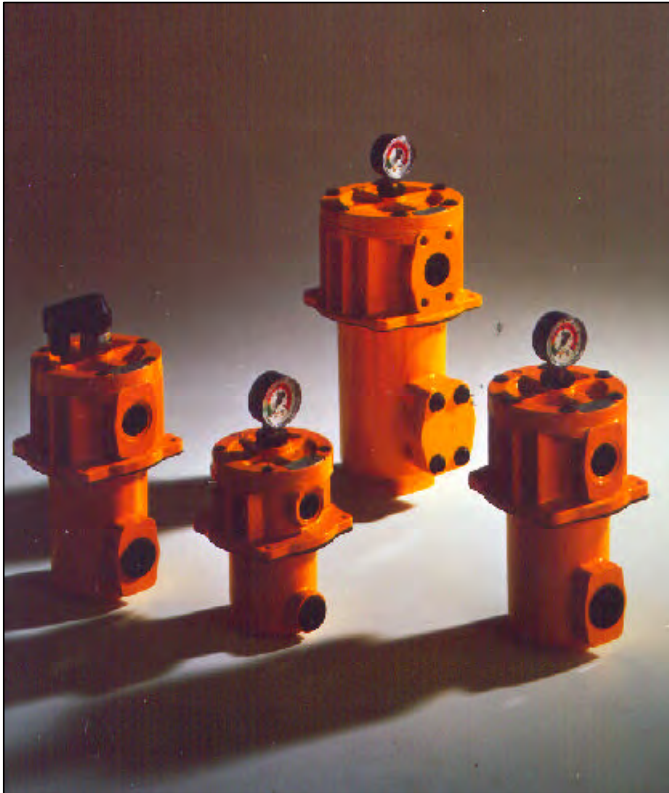

FAS SERIES - SUCTION FILTERS

FAS series filters are designed for a variety of filtration requirements for suction applications.

The particular design of these filters allows them to be mounted semi-immersed in the reservoir or inline.

FAS series filters are manufactured from aluminium alloy and are available in several sizes with flow rates up to 850 l/min (225 gpm). These filters are particularly suitable for stationary industrial applications, such as hydraulic presses, injection moulding machines and heavy industry.

FAS series filters can be supplied with contamination indicator, either visual or electrical.

A bypass valve, opening at 30 kPa (4.5 psi), can be supplied on request.

**MP** S.p.A. **FILTRI**



## TECHNICAL SPECIFICATIONS

**MATERIALS :**

Bowl:	Anodized Aluminium - Steel (only FAS 850)
Cover:	Anodized Aluminium
Seals:	"A" Series: Nitrile (Buna-N) / "V" Series: Viton
Filter element:	Square wire mesh
	End caps and tube: steel

**OPERATING TEMPERATURE RANGE :** From -25 to +110 °C

**BYPASS VALVE SETTING :** 30 KPa (4.5 psi) ±10% 10 KPa = 0.1 bar

**EFFECTIVE FILTER AREA OF FILTER ELEMENTS :**

FILTER ELEMENT TYPE	Area cm <sup>2</sup> (in <sup>2</sup> )
	M25 - M60 - M90 - M250
CU 025	280 (43 in <sup>2</sup> )
CU 040	480 (74 in <sup>2</sup> )
CU 100	770 (119 in <sup>2</sup> )
CU 250	1820 (282 in <sup>2</sup> )
CU 630	3450 (535 in <sup>2</sup> )
CU 850	11600 (1798 in <sup>2</sup> )

**FILTER HOUSING PRESSURE DROP :**

NOTE: The following diagrams were obtained using mineral oil with a density = 0,86 Kg/dm<sup>3</sup>

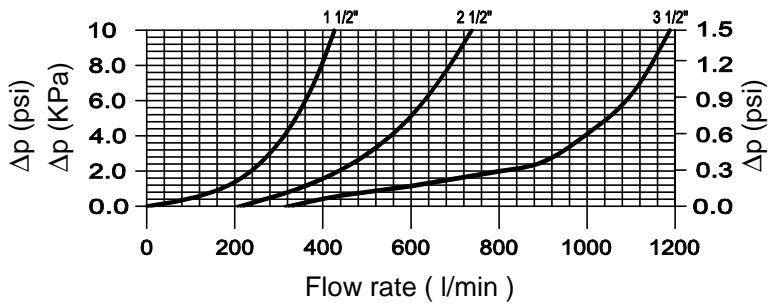
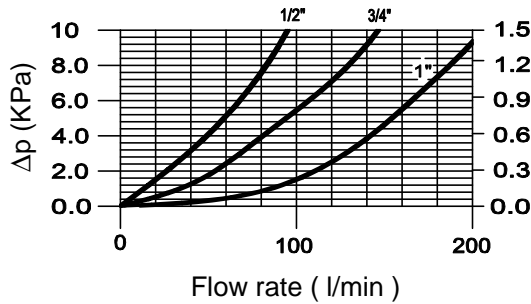

**FILTER ELEMENT PRESSURE DROP:**

NOTE:  
For calculating the pressure drop (KPa) of filter elements, the "K" coefficient shown in the table must be multiplied by the flow rate (l/min) . (The values refer to tests made using a mineral oil having a kinematic viscosity = 30 mm<sup>2</sup>/s = 150 SUS )

FILTER ELEMENT TYPE	"K" Coefficient			
	M25	M60	M90	M250
CU 025	0.072	0.051	0.040	0.032
CU 040	0.056	0.048	0.043	0.046
CU 100	0.040	0.033	0.026	0.021
CU 250	0.016	0.014	0.012	0.010
CU 630	0.013	0.010	0.0093	0.008
CU 850	0.0066	0.0057	0.005	0.0041

EXAMPLE:

Filter element type CA 100 M60 N

K coefficient = 0.033

Flow rate Q = 75 l/min

$$\Delta p = K \times Q = 0.033 \times 75 = 2.4 \text{ KPa}$$

$$( 2.4 \text{ KPa} \times 0.145 = 0.35 \text{ psi} )$$

**FILTER ASSEMBLY SIZING:**

For calculating the pressure drop of the filter assembly, the  $\Delta p$  of the filter housing must be added to the  $\Delta p$  of the filter element ( $\Delta p$  filter assembly =  $\Delta p$  filter housing +  $\Delta p$  filter element).

The values of "K" shown in the table refer to tests made using a mineral oil having a kinematic viscosity = 30 mm<sup>2</sup>/s (cSt). The  $\Delta p$  is proportional to the fluid kinematic viscosity. The maximum pressure loss for the complete assembly should be 8 KPa (1.2 psi).

**FAS SERIES - SUCTION FILTERS**

# DIMENSIONS

## FAS 025 - 630

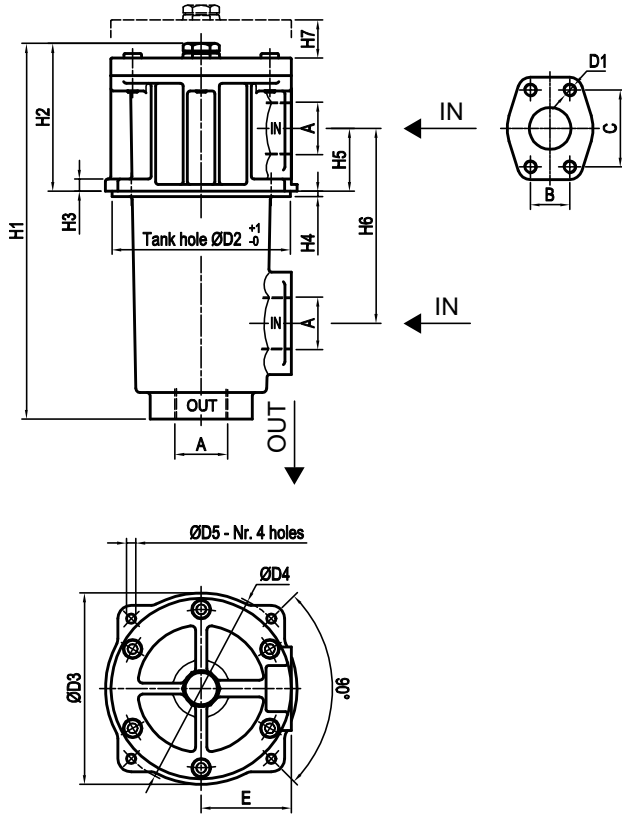

## FAS 850

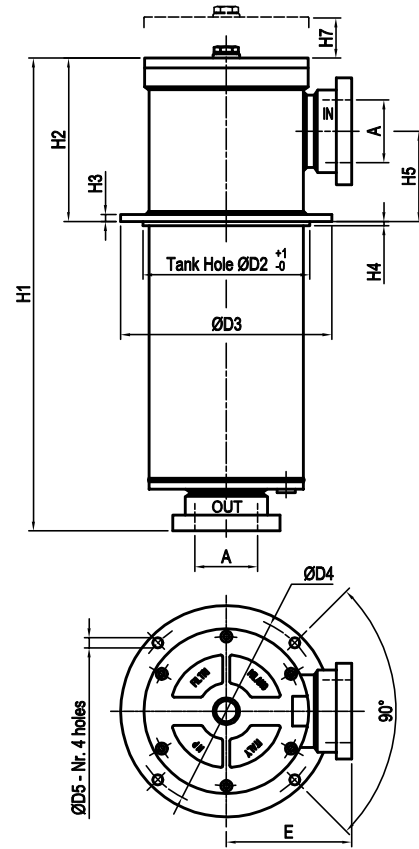

FAS SERIES - SUCTION FILTERS

### THREAD CONNECTIONS

FILTER TYPE	A		
	G1	G2	G3
FAS 025	G 1/2"	1/2" NPT	SAE 8 - 3/4" 16 UNF
FAS 040	G 3/4"	3/4" NPT	SAE 12 - 1 1/16" 12 UN
FAS 100	G 1"	1" NPT	SAE 16 - 1 5/16" 12 UN
FAS 250	G 1-1/2"	1 1/2" NPT	SAE 20 - 1 5/8" 12 UN
FAS 630	G 2-1/2"	2 1/2" NPT	SAE 32 - 2 1/2" 12 UN

### Indicators

### FLANGE CONNECTIONS

FILTER TYPE		A	B	C	D1
FAS 100	F1	1" SAE 3000 PSI / M	26.19	52.37	M10
	F2	1" SAE 3000 PSI / UNC	26.19	52.37	3/8" UNC
FAS 250	F1	1 1/2" SAE 3000 PSI / M	35.71	69.85	M12
	F2	1 1/2" SAE 3000 PSI / UNC	35.71	69.85	1/2" UNC
FAS 630	F1	2 1/2" SAE 3000 PSI / M	50.80	88.90	M12
	F2	2 1/2" SAE 3000 PSI / UNC	50.80	88.90	1/2" UNC
FAS 850	F1	3 1/2" SAE 3000 PSI / M	69.90	120.70	M16
	F2	3 1/2" SAE 3000 PSI / UNC	69.90	120.70	5/8" UNC

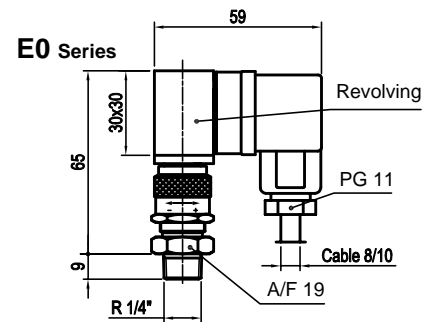

### FILTER

TYPE	H1	H2	H3	H4	H5	H6	H7	D2	D3	D4	D5	E
FAS 025	150	85	5	3	19	62.5	105	83.5	89	95	5.5	44
FAS 040	190	98	8	3.5	36	105	110	121	132	138	6.5	57
FAS 100	260	120	10	5	49	140	155	135	146	154	6.5	67
FAS 250	345	145	10	5	58	177	240	162	174	180	8.5	82
FAS 630	400	190	13	10	79	218	275	237	253	275	10.5	117.5
FAS 850	687	248	10	6	128	/	525	238	300	275	14.5	178

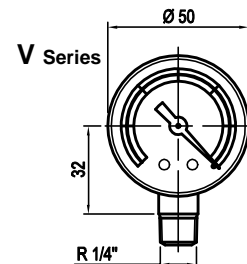

Note: All dimensions are in mm .

## HOW TO ORDER THE FILTER ASSEMBLY

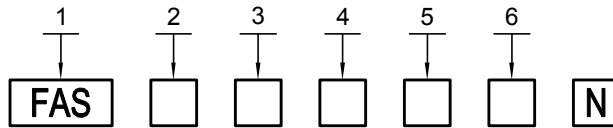

## HOW TO ORDER THE REPLACEMENT FILTER ELEMENT

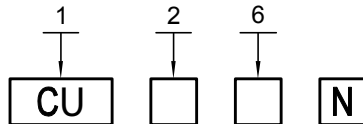

### 1 - FILTER SERIES

FAS - Suction Filter Assembly  
 CU - Filter element

### 2 - SIZE

025  
 040  
 100  
 250  
 630  
 850

### 3 - BYPASS VALVES

S - Without bypass valve  
 B - With bypass valve (setting = 30 KPa = 4,35 psi)

### 4 - SEALS

A - Nitrile (Buna N)  
 V - Viton

### FILTER INDICATOR:

T1 - Plug (no indicator)  
 V - Gauge at 20 kPa = 2.9 psi  
 E1 - Electrical indicator at 20 kPa = 2.9 psi

### 5 - PORT OPTIONS

CONNECTIONS						
TYPE	025	040	100	250	630	850
G1	G 1/2"	G 3/4"	G 1"	G 1 1/2"	G 2 1/2"	-
G2	1/2" NPT	3/4" NPT	1" NPT	1 1/2" NPT	2 1/2" NPT	-
G3	SAE 8	SAE 12	SAE 16	SAE 20	SAE 32	-
F1	-	-	1" SAE 3000 PSI/M	1 1/2" SAE 3000 PSI/M	2 1/2" SAE 3000 PSI/M	3 1/2" SAE 3000 PSI/M
F2	-	-	1" SAE 3000 PSI/UNC	1 1/2" SAE 3000 PSI/UNC	2 1/2" SAE 3000 PSI/UNC	3 1/2" SAE 3000 PSI/UNC

### 6 - FILTER MEDIA

M25     *Square wire mesh*     25  $\mu$ m  
 M60     *Square wire mesh*     60  $\mu$ m  
 M90     *Square wire mesh*     90  $\mu$ m  
 M250    *Square wire mesh*     250  $\mu$ m

