

Electronic pressure switch with display

Model PSD-30, standard version

Model PSD-31, with flush diaphragm

WIKA data sheet PE 81.67



Applications

- Machine tools
- Hydraulics and pneumatics
- Pumps and compressors
- Machine building

Special features

- Easily readable, robust display
- Intuitive and fast setup
- Easy and flexible mounting configurations



Electronic pressure switch, model PSD-30

Description

Award-winning in design and functionality

The successful design and the excellent functionality of the WIKA switch family were already confirmed by winning the “iF product design award 2009” for the PSD-30 pressure switch.

The robust LED display has been designed using 9 mm high characters (the largest possible) and with a slight incline in order to make reading the pressure as easy as possible from a long way off. A 14-segment display has been used, since it represents text very well.

The 3-key operation makes simple, intuitive menu navigation possible, with no need for additional assistance. The menu navigation conforms to the latest VDMA standard.

The VDMA standard for fluid sensors (24574-1, part 1 - pressure switches) has the aim of simplifying the use of pressure switches by standardising menu navigation and display.

The control keys have been designed as large as possible and are arranged ergonomically to ensure fast and easy adjustments. Operation without any additional assistance is made easier through the tactile feedback.

Customised installation

The installation of the PSD-30 and PSD-31 can be flexibly adapted to the individual mounting situation. Due to the almost unlimited rotation of the display and case by more than 300°, the display can be adjusted independently of the electrical connection. The display can thus always be aligned to face the operator, and the M12 x 1 connection positioned to suit the desired cable routing.

High quality

During development of the WIKA switch family a high value was placed on a robust design and the selection of appropriate materials suited to machine-building applications. For this reason the case and the threaded connection of the electrical connector are made from stainless steel. Overwinding or tearing off the connector is therefore virtually impossible.

IO-Link

With the optional output signal in accordance with the IO-Link communication standard, the PSD-30 and PSD-31 allow a fast integration into modern automation systems. IO-Link offers an even faster installation, parameterisation and higher functionality of the PSD-30 and PSD-31.

Measuring ranges

Gauge pressure								
bar	0 ... 1 ¹⁾	0 ... 1.6 ¹⁾	0 ... 2.5	0 ... 4	0 ... 6	0 ... 10	0 ... 16	0 ... 25
	0 ... 40	0 ... 60	0 ... 100	0 ... 160	0 ... 250	0 ... 400	0 ... 600	
psi	0 ... 15 ¹⁾	0 ... 25 ¹⁾	0 ... 30 ¹⁾	0 ... 50	0 ... 100	0 ... 160	0 ... 200	0 ... 300
	0 ... 500	0 ... 1,000	0 ... 1,500	0 ... 2,000	0 ... 3,000	0 ... 5,000	0 ... 8,000	
Absolute pressure								
bar	0 ... 1 ¹⁾	0 ... 1.6 ¹⁾	0 ... 2.5	0 ... 4	0 ... 6	0 ... 10	0 ... 16	0 ... 25
	psi	0 ... 15 ¹⁾	0 ... 25 ¹⁾	0 ... 30 ¹⁾	0 ... 50	0 ... 100	0 ... 160	0 ... 200
Vacuum and +/- measuring range								
bar	-1 ... 0 ¹⁾	-1 ... +0.6 ¹⁾	-1 ... +1.5	-1 ... +3	-1 ... +5	-1 ... +9	-1 ... +15	-1 ... +24
	psi	-14.5 ... 0 ¹⁾	-14.5 ... +15 ¹⁾	-14.5 ... +30	-14.5 ... +50	-14.5 ... +100	-14.5 ... +160	-14.5 ... +200

1) Not available for PSD-31.

Overpressure limit

2 times

1.7 times for the relative pressure measuring ranges 160 psi, 1,000 psi and 1,500 psi

Display

14-segment LED, red, 4-digit, 9 mm (0.35 inch) character size

Display can be turned electronically through 180°

Update (adjustable): 100, 200, 500 or 1,000 ms

Output signals

Switching output		Analogue signal
SP1	SP2	
PNP	-	4 ... 20 mA (3-wire)
PNP	-	DC 0 ... 10 V (3-wire)
PNP	PNP	-
PNP	PNP	4 ... 20 mA (3-wire)
PNP	PNP	DC 0 ... 10 V (3-wire)

Optionally also available with an NPN instead of a PNP switching output

IO-Link, revision 1.1 (option)

IO-Link is optionally available for all output signals.

With the IO-Link option, switching output SP1 is always PNP

Zero offset adjustment

max. 3 % of span

Switching thresholds

Switch point 1 and switch point 2 are individually adjustable

Switching functions

Normally open, normally closed, window, hysteresis

Freely adjustable

Switching voltage

Power supply - 1 V

Switching current

■ without IO-Link: max. 250 mA

■ with IO-Link: SP1 max. 100 mA
SP2 max. 250 mA

Settling time

Analogue signal: 3 ms

Switching output: ≤ 10 ms (20 ms with IO-Link)

Load

Analogue signal 4 ... 20 mA: ≤ 0.5 kΩ

Analogue signal DC 0 ... 10 V: > 10 kΩ

Service life

100 million switching cycles

Voltage supply

Power supply

DC 15 ... 35 V

Current consumption

Switching outputs with

- Analogue signal 4 ... 20 mA: 70 mA
- Analogue signal DC 0 ... 10 V: 45 mA
- without analogue signal: 45 mA

IO-Link option causes a deviating current consumption

Total current consumption

- without IO-Link: max. 600 mA including switching current
- with IO-Link: max. 450 mA including switching current

Accuracy specifications

Accuracy, analogue signal

$\leq \pm 1.0$ % of span

Including non-linearity, hysteresis, zero offset and end value deviation (corresponds to measured error per IEC 61298-2). Calibrated in vertical mounting position with process connection facing downwards.

Non-linearity: $\leq \pm 0.5$ % of span (BFSL, IEC 61298-2)

Long-term drift: $\leq \pm 0.2$ % of span (IEC 61298-2)

Accuracy, switching output

Switch point accuracy: $\leq \pm 1$ % of span

Adjustment accuracy: $\leq \pm 0.5$ % of span

Display

$\leq \pm 1.0$ % of span ± 1 digit

Temperature error in rated temperature range

- typical: $\leq \pm 1.0$ % of span
- maximum: $\leq \pm 2.5$ % of span

Temperature coefficients in rated temperature range

Mean TC zero point: $\leq \pm 0.2$ % of span/10 K (typical)

Mean TC span: $\leq \pm 0.1$ % of span/10 K (typical)

Reference conditions

Temperature: 15 ... 25 °C (59 ... 77 °F)

Atmospheric pressure: 950 ... 1,050 mbar (13.78 ... 15.23 psi)

Humidity: 45 ... 75 % r. h.

Nominal position: Process connection lower mount (LM)

Power supply: DC 24 V

Load: see output signals

Operating conditions

Permissible temperature ranges

Medium: -20 ... +85 °C (-4 ... +185 °F)

Ambient: -20 ... +80 °C (-4 ... +176 °F)

Storage: -20 ... +80 °C (-4 ... +176 °F)

Nominal temperature: 0 ... 80 °C (32 ... 176 °F)

Humidity

45 ... 75 % r. h.

Vibration resistance

10 g (IEC 60068-2-6, under resonance)

Shock resistance

50 g (IEC 60068-2-27, mechanical)

Service life, mechanics

100 million load cycles (10 million load cycles for measuring ranges > 600 bar/7,500 psi)

Ingress protection

IP 65 and IP 67

The stated ingress protection (per IEC 60529) only applies when plugged in using mating connectors that have the appropriate ingress protection.

Mounting position

as required

Materials

Wetted parts

Process connection: Stainless steel 316L

Pressure sensor: < 9.8 bar: Stainless steel 316L
≥ 9.8 bar: Stainless steel 13-8 PH

Non-wetted parts

Case: Stainless steel 304

Keyboard: TPE-E

Display window: PC

Display head: PC+ABS-Blend

Options for specific media

Medium	Option
Oil and grease free	Residual hydrocarbon: < 1,000 mg/m ²
Oxygen, oil and grease free	<ul style="list-style-type: none">■ Residual hydrocarbon: < 200 mg/m²■ Packaging: Protection cap on the process connection■ Maximum permissible temperature -20 ... +60 °C (-4 ... +140 °F)■ Only available for PSD-30■ Available measuring ranges:<ul style="list-style-type: none">- 0 ... 10 to 0 ... 400 bar gauge- -1 ... 9 to -1 ... 24 bar■ Factory supplied without sealing

Process connections

Available connections, model PSD-30

Standard	Thread
DIN 3852-E	G ¼ A G ½ A
EN 837	G ¼ B G ¼ female G ½ B
ANSI/ASME B1.20.1	¼ NPT ½ NPT
ISO 7	R ¼
KS	PT ¼
-	G ¼ female (Ermeto compatible)

Other connections on request.

Available connections, model PSD-31

Standard	Thread
-	G ½ B with flush diaphragm

Sealings

Process connection per DIN 3852-E	
Standard	NBR
Option 1	without
Option 2	FPM/FKM

Process connection per EN 837 ¹⁾	
Standard	without
Option 1	Copper
Option 2	Stainless steel

1) Process connections per EN 837 with female threads do not include any seal.

Process connection G ½ B flush	
Standard	NBR
Option	FPM/FKM

Electrical connections

Connections

- Circular connector M12 x 1 (4-pin)
- Circular connector M12 x 1 (5-pin) ¹⁾

1) Only for version with two switching outputs and additional analogue signal

Electrical safety

Short-circuit resistance: S₊ / SP1 / SP2 vs. U₋

Reverse polarity protection: U₊ vs. U₋

Insulation voltage: DC 500 V

Overvoltage protection: DC 40 V

Connection diagram

Circular connector M12 x 1 (4-pin)



U ₊	1
U ₋	3
S ₊	2
SP1/C	4
SP2	2

Circular connector M12 x 1 (5-pin)



U ₊	1
U ₋	3
S ₊	5
SP1/C	4
SP2	2

Legend:

- U₊ Positive power supply
- U₋ Reference potential
- SP1 Switching output 1
- SP2 Switching output 2
- C Communication with IO-Link
- S₊ Analogue output

CE conformity

Pressure equipment directive

97/23/EC

EMC directive

2004/108/EC, EN 61326 emission (group 1, class B) and interference immunity (industrial application)

Manufacturer's declaration

RoHS conformity

2011/65/EU

Approvals

- **cULus**, safety (e.g. electr. safety, overpressure, ...), USA, Canada
- **EAC**, import certificate, customs union Russia/Belarus/Kazakhstan
- **CRN**, safety (e.g. electr. safety, overpressure, ...), Canada

Approvals and certificates, see website

Dimensions in mm (inch)

Pressure switch with circular connector M12 x 1 (4-pin and 5-pin)

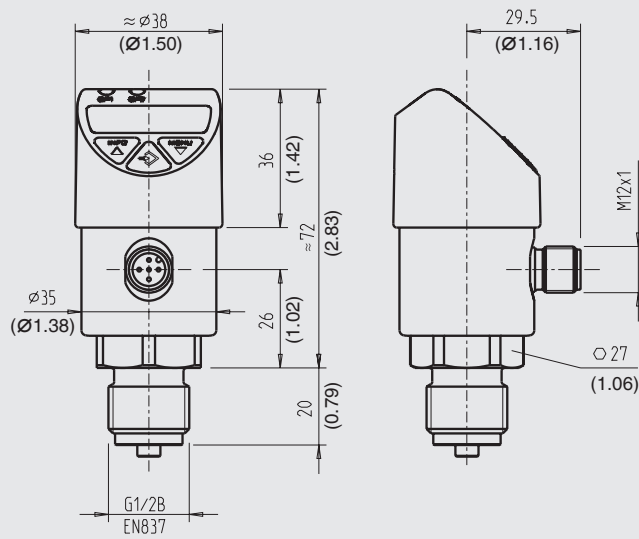

Weight: approx. 220 g (7.76 oz)

Process connections, model PSD-30

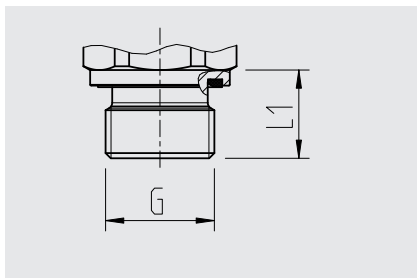

G	L1
G ¼ A DIN 3852-E	12 (0.47)
G ½ A DIN 3852-E	14 (0.55)

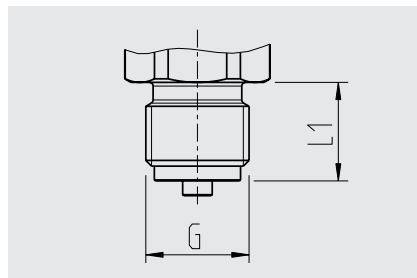

G	L1
G ¼ B EN 837	13 (0.51)
G ½ B EN 837	20 (0.79)

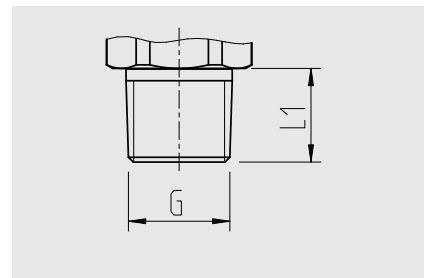

G	L1
¼ NPT	13 (0.51)
½ NPT	19 (0.75)
R ¼	13 (0.51)
PT ¼	13 (0.51)

Process connections, model PSD-30

Female thread

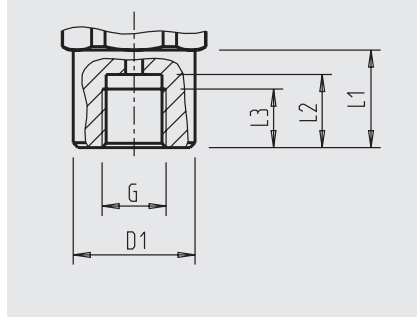

G	L1	L2	L3	D1
G ¼ ¹⁾	20 (0.79)	15 (0.59)	12 (0.47)	Ø 25 (Ø 0.98)

Female thread

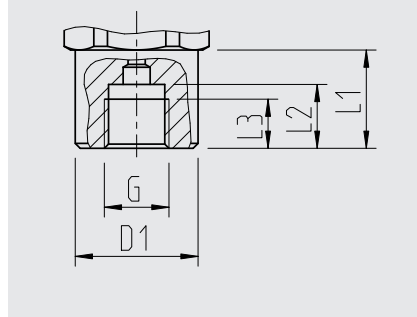

G	L1	L2	L3	D1
G ¼ EN 837	20 (0.79)	13 (0.51)	10 (0.39)	Ø 25 (Ø 0.98)

Process connection, model PSD-31

Flush

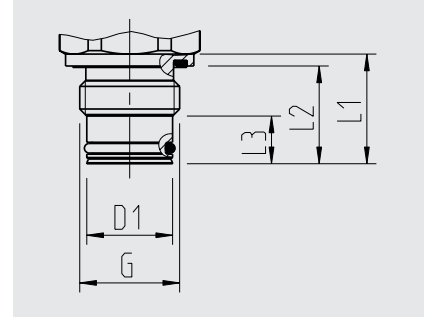



G	L1	L2	L3	D1
G ½ B ²⁾	23 (0.91)	20.5 (0.81)	10 (0.39)	Ø 18 (Ø 0.71)



1) Ermeto compatible

2) Welding sockets recommended as defined counter-thread (see accessories)

Accessories and spare parts

Welding socket		
	Description	Order no.
	G ½ B female, outer diameter 50 mm (2 in), material 1.4571	1192299

Sealings		
	Description	Order no.
	NBR profile sealing G ¼ A DIN 3852-E	1537857
	FPM/FKM profile sealing G ¼ A DIN 3852-E	1576534
	NBR profile sealing G ½ A DIN 3852-E	1039067
	FPM/FKM profile sealing G ½ A DIN 3852-E	1039075
	Copper G ¼ B EN 837	11250810
	Stainless steel G ¼ B EN 837	11250844
	Copper G ½ B EN 837	11250861
	Stainless steel G ½ B EN 837	11251042

Connectors with moulded cable					
	Description	Temperature range	Cable diameter	Order no.	
	Straight version, cut to length, 4-pin, 2 m (6.6 ft) PUR cable, UL listed, IP 67	-20 ... +80 °C (-4 ... 176 °F)	4.5 mm (0.18 in)	14086880	
	Straight version, cut to length, 4-pin, 5 m (16.4 ft) PUR cable, UL listed, IP 67	-20 ... +80 °C (-4 ... 176 °F)	4.5 mm (0.18 in)	14086883	
	Straight version, cut to length, 4-pin, 10 m (32.8 ft) PUR cable, UL listed, IP 67	-20 ... +80 °C (-4 ... 176 °F)	4.5 mm (0.18 in)	14086884	
	Straight version, cut to length, 5-pin, 2 m (6.6 ft) PUR cable, UL listed, IP 67	-20 ... +80 °C (-4 ... 176 °F)	5.5 mm (0.22 in)	14086886	
	Straight version, cut to length, 5-pin, 5 m (16.4 ft) PUR cable, UL listed, IP 67	-20 ... +80 °C (-4 ... 176 °F)	5.5 mm (0.22 in)	14086887	
	Straight version, cut to length, 5-pin, 10 m (32.8 ft) PUR cable, UL listed, IP 67	-20 ... +80 °C (-4 ... 176 °F)	5.5 mm (0.22 in)	14086888	
		Angled version, cut to length, 4-pin, 2 m (6.6 ft) PUR cable, UL listed, IP 67	-20 ... +80 °C (-4 ... 176 °F)	4.5 mm (0.18 in)	14086889
		Angled version, cut to length, 4-pin, 5 m (16.4 ft) PUR cable, UL listed, IP 67	-20 ... +80 °C (-4 ... 176 °F)	4.5 mm (0.18 in)	14086891
Angled version, cut to length, 4-pin, 10 m (32.8 ft) PUR cable, UL listed, IP 67		-20 ... +80 °C (-4 ... 176 °F)	4.5 mm (0.18 in)	14086892	
Angled version, cut to length, 5-pin, 2 m (6.6 ft) PUR cable, UL listed, IP 67		-20 ... +80 °C (-4 ... 176 °F)	5.5 mm (0.22 in)	14086893	
Angled version, cut to length, 5-pin, 5 m (16.4 ft) PUR cable, UL listed, IP 67		-20 ... +80 °C (-4 ... 176 °F)	5.5 mm (0.22 in)	14086894	
Angled version, cut to length, 5-pin, 10 m (32.8 ft) PUR cable, UL listed, IP 67		-20 ... +80 °C (-4 ... 176 °F)	5.5 mm (0.22 in)	14086896	

Cooling element for screwing G ½ female / G ½ male (for instruments with process connection G ½ B)		
	Description	Order no.
	Max. medium temperature 150 °C (302 °F) at an ambient temperature of max. 30 °C (86 °F) Max. operating pressure 250 bar (3,626 psi)	14055439
	Max. medium temperature 200 °C (392 °F) at an ambient temperature of max. 30 °C (86 °F) Max. operating pressure 250 bar (3,626 psi)	14055438

Instrument mounting bracket

Description	Order no.
	11467887

Ordering information

Model / Measuring range / Output signal / Process connection / Accessories and spare parts

© 2011 WIKA Alexander Wiegand SE & Co. KG, all rights reserved.
The specifications given in this document represent the state of engineering at the time of publishing.
We reserve the right to make modifications to the specifications and materials.



WIKAI Alexander Wiegand SE & Co. KG
Alexander-Wiegand-Straße 30
63911 Klingenberg/Germany
Tel. +49 9372 132-0
Fax +49 9372 132-406
info@wika.de
www.wika.de